

95 FEB 21 AM 9:56
RECORDED BY J. DODD
RECORDER 4322

ADDITIONAL SURVEY DATA

- 1 N 83° 03' 26" E - 38.00'
- 2 N 68° 51' 33" E - 48.00'
- 3 N 56° 53' 26" E - 65.00'
- 4 N 50° 36' 15" E - 5.02'
- 5 N 52° 28' 08" E - 79.00'
- 6 N 59° 20' 54" E - 62.00'
- 7 N 65° 35' 45" E - 59.00'
- 8 N 65° 55' 22" E - 8.67'
- 9 N 70° 38' 50" E - 78.29'
- 10 N 75° 46' 09" E - 37.66'
- 11 S 88° 30' 07" E - 51.40'
- 12 S 83° 23' 49" E - 23.97'
- 13 S 83° 21' 24" E - 93.00'
- 14 S 80° 40' 21" E - 50.00'
- 15 S 80° 39' 24" E - 57.00'
- 16 S 80° 40' 21" E - 104.51'
- 17 S 73° 02' 45" E - 75.02'
- 18 S 52° 50' 42" E - 32.18'
- 19 S 52° 50' 24" E - 44.54'
- 20 S 62° 10' 59" E - 68.34'
- 21 S 74° 00' 30" E - 35.13'
- 22 S 86° 12' 45" E - 51.99'
- 23 S 89° 12' 50" E - 30.00'
- 24 S 78° 52' 44" E - 111.89'
- 25 DELTA: 64°00'37" TAN: 31.25' RAD: 50.00' ARC: 30.86'
CHD. DIST.: 53.00' CHD. BEARING: N 53°18'30" E
- 26 DELTA: 106°37'36" TAN: 67.11' RAD: 50.00' ARC: 93.05'
CHD. DIST.: 80.19' CHD. BEARING: S 42°29'17" E
- 27 S 44° 33' 52" E - 123.50'
- 28 DELTA: 128°49'34" TAN: 104.42' RAD: 50.00' ARC: 112.42'
CHD. DIST.: 90.19' CHD. BEARING: N 74°41'27" W
- 29 S 78° 52' 45" W - 115.90'
- 30 N 86° 12' 47" W - 96.50'
- 31 N 74° 00' 33" W - 45.65'
- 32 N 62° 10' 58" W - 77.61'
- 33 N 52° 50' 49" W - 30.00'
- 34 N 52° 50' 25" W - 41.90'
- 35 N 78° 02' 48" W - 62.78'
- 36 N 80° 40' 22" W - 207.26'
- 37 N 83° 21' 25" W - 113.31'
- 38 N 88° 30' 09" W - 42.24'
- 39 S 75° 46' 11" W - 28.51'
- 40 S 70° 38' 54" W - 73.99'
- 41 S 65° 55' 14" W - 62.74'
- 42 S 58° 58' 37" W - 59.12'
- 43 S 84° 07' 30" E - 57.05'
- 44 S 68° 30' 12" E - 130.19'
- 45 S 00° 05' 55" E - 51.72'
- 46 N 64° 50' 35" W - 41.12'
- 47 N 68° 30' 09" W - 103.81'
- 48 N 82° 38' 56" W - 38.25'
- 49 S 87° 00' 02" W - 29.70'
- 50 S 87° 00' 24" W - 48.90'
- 51 S 56° 53' 25" W - 61.02'
- 52 S 68° 51' 29" W - 56.79'
- 53 S 62° 26' 28" W - 57.85'

ACREAGE

AREA	TOTAL	TOWNSHIP	
		CAMBRIDGE	CENTER
LOTS (1 THRU 14)	18.749	5.192	13.557
ROADWAYS	2.361	1.200	1.161
COMMON AREA	45.743	6.957	38.786
GRAND TOTALS	66.853	13.349	53.504

RICHARD K. & TERRI S. SABO
VOLUME 354
PAGE 523

CHARLES E. & MARILYN L. GIBSON
VOLUME 354
PAGE 647

NIZAR ORFAHLT
ORB 66
PAGE 864

SUZANNE STRAWSBURG
VOLUME 354
PAGE 916

COMMONS AREA

COMMONS AREA

COMMONS AREA
45.743 TOTAL ACRES OF COMMON AREA

COMMONS AREA

FILED FOR RECORD THIS 21ST DAY OF FEBRUARY, 1995
AT 9:56 O'CLOCK A.M., RECORDED IN THE FOLLOWING
PLAT BOOK:
CAMBRIDGE, Side 99b

Guernsey County Recorder
Joseph T. Spilker
Ben J. Dodd

2/21/95
DATE

CERTIFICATE OF SURVEYOR:

I HEREBY CERTIFY THAT AT THE DIRECTION OF JOHN PELLEGRINI AND JULIE PELLEGRINI, OWNERS OF THE REAL ESTATE SHOWN, I SURVEYED AND PLATTED 18,749 ACRES OF THE SAME INTO LOTS, 45,743 ACRES INTO COMMON AREA, AND 2,361 ACRES INTO ROADWAYS, FOR A TOTAL OF 66,853 ACRES, MORE OR LESS, AS SHOWN. SAID LOTS HAVE BEEN NUMBERED 1 TO 14, INCLUSIVE, THE COMMON AREAS ARE SO DENOTED ON THE PLAT, AND THE FOREGOING REAL ESTATE HAS BEEN NAMED THE WOODLANDS AT BARRETT HILL, AND THE DIMENSIONS ARE GIVEN IN FEET AND DECIMAL PARTS THEREOF. IRON PINS ARE PLACED AS SHOWN FOR THE REGULATION OF FUTURE SURVEYS.

DEED REFERENCES:
CENTER TOWNSHIP TAX MAP I.D. #2
O.R.B. # 84, PAGE 740
PARCEL NO.: 08-01781
CAMBRIDGE TOWNSHIP MAP I.D. #15
O.R.B. #94, PAGE 740
PARCEL NO.: 02-04125-004

CAMBRIDGE TOWNSHIP MAP I.D. #15
O.R.B. #94, PAGE 272
PARCEL NO.: 02-04125

Joseph T. Spilker
REGISTERED SURVEYOR #5862

10-27-94
DATE

LEGEND

- ▲ P. K. NAIL SET
- POINT
- IRON PIN SET
- IRON PIN FOUND
- 1" REBAR SET
- STONE FOUND
- PROPERTY LINE
- - - SECTION / TOWNSHIP BOUNDARY
- - - UTILITY EASEMENT/RIGHT-OF-WAY
- - - BUILDING SET BACK
- - - ACCESS ROAD CENTERLINE

REVISIONS	BY

THE WOODLANDS
AT BARRETT HILL
CAMBRIDGE, OHIO 43725
PROPERTY & PLAT PLANS
LOTS, COMMON AREA, ROADWAYS

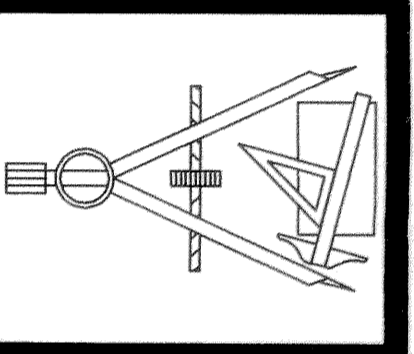

JAMES M. & SANDRA K. HINSON
VOLUME 371
PAGE 294

Spilker Surveying
744 1/2 SOUTH 9TH STREET
CAMBRIDGE, OHIO 43725
(614) 439-2057

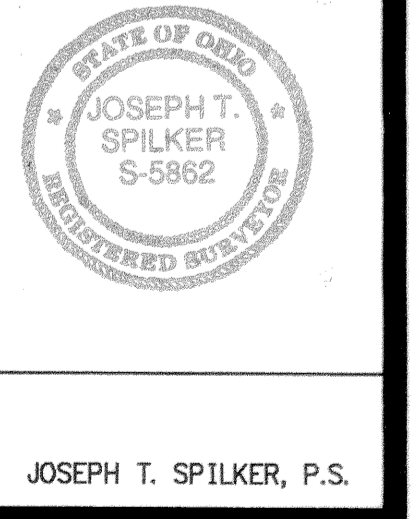

JOSEPH T. SPILKER, P.S.

DRAWN
G. DIMENT
DATE
OCTOBER 24, 1994
SCALE
1" = 100'-0"
JOB NO.
007-001

DRAFTING BY:
Micro-Computer Design Services
204 Watson Avenue
Cambridge, Ohio 43725
614-432-3864
THIS DRAWING IS NOT TO BE SCALED FOR THE PURPOSE OF CONSTRUCTION OR FABRICATION. DIMENSIONS PROVIDED ON THE DRAWING SHOULD BE USED DURING CONSTRUCTION OR FABRICATION.